



LITESPEED S

owners manual

CONTENTS

Amendments.....	2
Introduction	3
Description of Design.....	4
Specifications	5
Operating Limitations	6
Disclaimer.....	7
Getting Started	8
Assembly Procedures	12
Pre-Flight Check	17
De-Rigging the Litespeed S.....	19
Flying the Moyes Litespeed S.....	23
Tuning Hints.....	27
Performance Tuning.....	29
Glider Care.....	31
Maintenance Schedule.....	33
Sail Removal.....	34
Checking The Litespeed S Stability System	35
Purchase Record.....	36
AN Bolt Index & Maintenance Log.....	37
Exploded View Drawings	37-45

AMENDMENTS

Version	Date	Changes
1.00	7/8/2003	<ul style="list-style-type: none">• Created original owners manual
1.01	20/8/2003	<ul style="list-style-type: none">• Updated parts diagrams and removed List of Fasteners and Airframe Bolts. The list is not required with the diagrams.
1.02	10/12/2003	<ul style="list-style-type: none">• Corrected Phone number on cover page.
1.03	27/02/2004	<ul style="list-style-type: none">• Added details for fitting Carbon Rear Leading Edge.• Changed stability settings
1.04	5/05/2004	<ul style="list-style-type: none">• Added parts drawing for Zoom Upright Assembly• Changed instructions for Stability System
1.05	27/4/2005	<ul style="list-style-type: none">• Safety note stability settings• Removed stability settings & moved purchase record
1.06	17/10/2005	<ul style="list-style-type: none">• Updated manual to include the Litespeed S 3• Updated glider specifications for the new version

INTRODUCTION

Thank you for choosing the Moyes Litespeed S. You have chosen wisely. The Litespeed S incorporates the latest high performance hang gliding design technology.

Since 1967, Moyes Delta Gliders has strived to be on the cutting edge of developing hang gliders of the highest calibre. A family owned business operating under homespun values, we aim to provide a comprehensive international network to service all pilots. Even further, we work with some of the best pilots in the world to ensure that our gliders are stringently made and tested in order to improve their performance, handling, and safety.

We wish you the very best flying,
The Moyes Team



Moyes Delta Gliders Pty. Ltd.

1144 Botany Road, Botany NSW 2019 Australia T: +61 (0)2 9316-4644 F: +61 (0)2 9316-8488 E: moyes@moyes.com.au

WWW.MOYES.COM.AU

DESCRIPTION OF DESIGN

The Moyes Litespeed S is the next evolution in modern flex wing hang glider design. The "S" refers to the latest sail cut design being applied to the Litespeed, and you'll understand why when you look along the trailing edge. Sail area has been removed from the chord or root of the sail and redistributed to the mid and outer wing. This results in an "S" shape along the trailing edge – or in more technical terms – a "super-elliptic" wing planform.

The sail cut of the new Litespeed S intends to counteract the typical mid-wing lift deficit of flexible hang gliders. The creation of a super elliptic wing planform in other words just compensates chord wise for the inevitable washout of flex wings - resulting in a better, more elliptic lift distribution. A wider mid wing and tip cord allows more of the outer wing to create lift along the wing span – the glider's effective aspect ratio thus increases without additional span.

The Litespeed S features a 7075 aluminium airframe which allows minimum weight with excellent flex characteristics. The leading edge features a step down taper design with revised sleeving and tube diameters to produce a lighter weight outer leading edge with improved flex distribution across the length. The weight reduction provides considerable reduction of inertia and thus roll pressures are minimal.

The elliptical fibre glass wing tip has been a feature of Moyes high performance gliders since the early 80's. The fibre glass tip creates a washout distribution allowing better turning coordination than conventional designs. With the full tight VG setting, the fibre glass tip allows for a tighter mainsail and a more desirable washout distribution.

The pitch stability system utilises cable braced inner and outer aluminium sprogs providing support for battens 7 to 11 via two transversal battens. The inner sprog features a unique compensator system operating from the geometrical change of the X-bar to leading edge angle. This allows for the inner sprog to rise 80mm when the VG is released. The stability system was designed with maximum strength and stiffness in mind, and demonstrates excellent structural integrity under any flight load.

The Litespeed S sail has a total of 8 internal cloth ribs. These internal ribs restrict the under surface from 'blowing out' which prevents pilot induced oscillations. The internal ribs are cut to a specific airfoil, which produces the desired under surface camber for low drag high speed gliding.

The Litespeed S features a spar constructed entirely of pre-impregnated carbon fibre cloth. The pre-impregnated carbon provides maximum consistency in production. The spar utilises combinations of biaxial fibre and unidirectional fibre to produce load absorbing flexibility and maximum impact resistance.

The Litespeed S also hosts a range Carbon Fibre options aimed at reducing wing tip inertia, thus greatly enhancing handling. These options include Carbon Fibre outer Leading Edge, Carbon Fibre Divesticks and a Lightened Crossbar.

SPECIFICATIONS

Model Size	Litespeed S 3	Litespeed S 3.5	Litespeed S 4	Litespeed S 4.5	Litespeed S 5
Area	12.9 sq m	13.6 sq m	14 sq m	14.4 sq m	14.8 sq m
	139 sq ft	146 sq ft	151 sq ft	155 sq ft	159 sq ft
Span	9.7 m	10 m	10 m	10.4 m	10.4 m
	31.8.8 ft	32.8 ft	32.8 ft	34 ft	34 ft
Nose Angle	130 to 132 deg	130 to 132 deg	130 to 132 deg	130 to 132 deg	130 to 132 deg
Aspect Ratio	7.3	7.5	7.3	7.6	7.4
Glider Weight	32 kg	33.6 kg	33.6 kg	34.5 kg	34.5 kg
	71 lb	74 lb	74 lb	76 lb	76 lb
Optimal Pilot Weight	55 kg	68 kg	75 kg	85 kg	90 kg
	121 lbs	150 lbs	165 lb	187 lb	198 lb
Hook-In-Weight	60-80 kg	68-109 kg	68-109kg	75-120kg	75-120kg
	132-176 lb	150-240 lb	150-240 lb	165-265 lb	165-265 lb
Packed-Length	4900 mm	4950 mm	4950 mm	5150 mm	5150mm
	16.1 ft	16.2 ft	16.2 ft	16.9 ft	16.9 ft
Short-Packed Length	3800 mm	4330 mm	4330 mm	4500mm	4500mm
	12.5 ft	14.2 ft	14.2 ft	14.8 ft	14.8 ft
C of G Front of Keel	1310 mm	1343mm	1353 mm	1360mm	1370mm
	51.6 inches	52.9 inches	53.3 inches	53.5 inches	53.9"
Number of Battens:					
	Mainsail	21	23	23	23
Undersurface	6	6	6	6	6
VNE	85kph	85kph	85kph	85kph	85kph
	53mph	53mph	53mph	53mph	53mph
VA	74kph	74kph	74kph	74kph	74kph
	46mph	46mph	46mph	46mph	46mph
Trim Speed	34kph	34kph	34kph	34kph	34kph
	21mph	21mph	21mph	21mph	21mph
Stall Speed	26kph	26kph	26kph	26kph	26kph
	16mph	16mph	16mph	16mph	16mph
Max Speed	124kph	124kph	124kph	124kph	124kph
	77mph	77mph	77mph	77mph	77mph
Best Glide Speed	45kph	45kph	45kph	45kph	45kph
	28mph	28mph	28mph	28mph	28mph
Best Glide Angle	15:1	15:1	15:1	15:1	15:1
Glide Angle 10:1	74kph	74kph	74kph	72kph	72kph
	46mph	46mph	46mph	45mph	45mph

OPERATING LIMITATIONS

Your Moyes Litespeed S is a sophisticated state of the art high performance hang glider. If maintained correctly it will give you years of safe enjoyable soaring. However, it is important that you display a healthy respect for all aspects of aviation and that you especially understand the increased risks of flying in dangerous conditions or in a manner that exceeds the glider's operating limitations.

- Flight operation should be limited to non-aerobatic manoeuvres where the pitch angle doesn't exceed 30 degrees up and down to the horizon and bank angles don't exceed 60 degrees
- The Moyes Litespeed S has been designed for foot launched soaring flight and should not be flown by more than one person at a time
- It should not be flown backwards or inverted
- The recommended minimum pilot skill level is Advanced (Hang 4)
- The Moyes Litespeed S should not be flown with auxiliary power
- The Moyes Litespeed S should not be flown in excess of the placarded VNE or VA
- VNE (speed never to exceed): 53 mph / 84.8 kph
- VA (maximum rough air manoeuvring speed): 46 mph / 73.6 kph
- Stall speed with maximum pilot weight: Less than 25 mph / 40 kph
- Maximum speed with minimum pilot weight: Less than 55 mph / 80 kph

The Moyes Litespeed S will resist spinning and will recover quickly if control pressures are relaxed. Recovery from a stalled turn can be achieved without extreme height loss or without extreme attitude change if the angle of attack is reduced. Recovery from such an incipient spin will be achieved within half a turn if the angle of attack is lowered to a normal flying angle.

The Moyes Litespeed S has been tested and certified to the USHGMA and DHV standards. These standards require ultimate load tests at:

- Maximum lift angle of attack at a speed of 65 mph / 104 kph
- Negative 30 degrees angle of attack at a speed of 46 mph / 73.6 kph
- Negative 150 degrees angle of attack at a speed of 32 mph / 51.2 kph
- Pitching moment tests at 20/32, 37/59 and 54/86 mph/kph respectively, to display the gliders inherent positive pitch stability through a broad range of angles of attack

The Moyes Litespeed S is capable of easily flying at speeds greater than the VA and VNE. We recommend you use an accurate airspeed indicator and familiarise yourself with control bar positions at these speeds and normal flying speeds.

DISCLAIMER

The owner and operator must understand that due to the inherent risk involved in flying such a unique vehicle, no warranty is made or implied of any kind against accidents, bodily injury or death. Operations such as aerobatic manoeuvres or erratic pilot technique may ultimately produce equipment failure, and are specifically excluded from the warranty.

This glider is not covered by product liability insurance, nor has it been designed, manufactured or tested to any state or federal government airworthiness standards or regulations.

GETTING STARTED

Your new Moyes Litespeed S may have been shipped to you in the 4.5 metre breakdown form. If so, you can assemble your glider to its full length by following the assembly procedures. All references to 'top' & 'bottom' and 'left' and 'right' are referred to with the glider in flying mode.

Please check your packing list

- Glider
- 2 x Back section leading edges: note that the back sections are different between left and right
- 1 x Batten Set: Right=Green/Left=Red/Blue=Undersurface
- 1 x Speed Bar
- 2 x Tip Bags
- 3 x Padding Pieces: A-Frame top & bottom, Keel sleeve
- 1 x Batten Pattern
- 1 x Snack Pack with owner's manual and Batten Profile

Assembly from 4.5m Breakdown Form

1. Open the glider bag and roll the glider onto its undersurface. Undo the straps and extend the sail.

Picture 1

Lay the glider on its undersurface and unfold the sail.

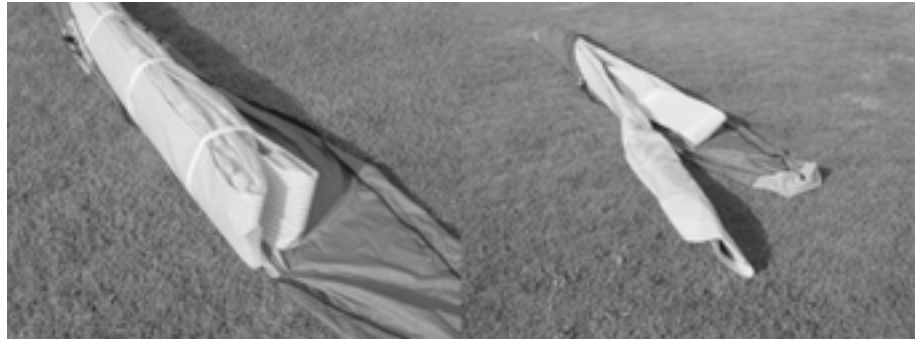

2. Expose the leading edge/cross bar junction through the inspection zip. Remove the bubble wrap and tape from the leading edge/cross bar junction and the end of the middle sleeve.

Picture 2

Remove packing materials from leading edge end.



3. Aluminium Rear Leading Edge

Insert the right hand back section of leading edge. The right hand back section differs from the left in the mounting of the outer sprog. You can check this by picturing that the cable must be on the top side of the leading edge and the sprog must fold inboard. Push the back section into the mid sleeve while depressing the push button pin. Continue to push the back section in until it reaches its stop, then rotate the back section until the mid sleeve location holes align with the push button pin. Closely check that the push button pin has fully released and that the back section is secure against rotation forces.

Picture 3

Insert the back ends of the leading edge.

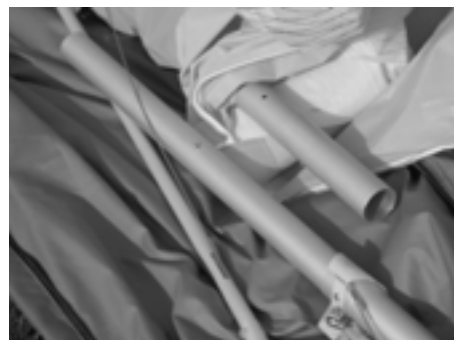

Carbon Rear Leading Edge

- a. Remove the clevis pin and safety ring from the aluminium leading edge via the inboard dive stick zipper on the undersurface of the right wing.



- b. Access the back end of the aluminium leading edge via the outboard dive stick zipper. Note the position of the mid eccentric ring locating screw, as the eccentric ring must be refitted to the exact same position. Remove the retention screw and the mid eccentric ring from the leading edge.

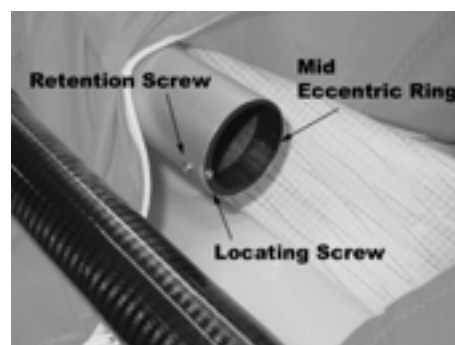

- c. Select the right carbon rear leading edge (RLE). This can be done by extending the dive strut. The dive strut wire must be on the top of the leading edge to support the dive stick.
- d. Fit the mid eccentric ring over the carbon rear leading edge.

- e. With the outer dive stick folded towards the nose of the glider, slide the carbon rear leading edge into the sail via the glass tip pocket, allowing the outer dive stick to exit the sail at the undersurface zipper. Insert the carbon rear leading edge into the aluminium leading edge.



- f. Refit the clevis pin and safety pin, ensuring the pin goes through the holes at the end of the carbon rear leading edge.
- g. Slide the mid eccentric ring into the end of the aluminium leading edge, ensuring its location is the same as when it was removed. Insert the retention screw.

! NOTE

The rear leading edges are marked "RLE". This is an abbreviation of "Rear Leading Edge", not right leading edge. The left and right side RLE's must be identified by ensuring dive strut wire is on top of the leading edge.

4. Secure the sail by attaching to the tip webbing using the clevis pin and ring supplied. Insert the pin through the webbing and into the bottom hole at an angle. Straighten the clevis pin while sliding the webbing towards the leading edge as shown in Picture 4. Ensure the tip webbing is not twisted and is on the bottom of the leading edge.

Picture 4

Insert sail pin into end of leading edge

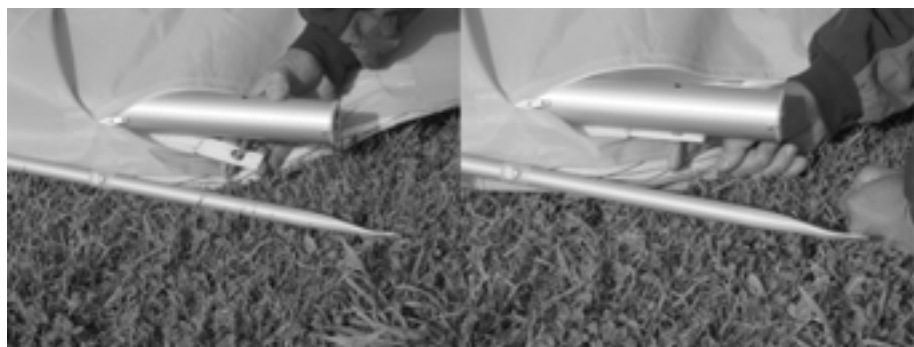

5. Repeat steps 1-4 to install the left hand back section of leading edge. Your Litespeed will now be ready for the standard assembly. Before flight, make a thorough inspection of all tubing and nuts and bolts to ensure no damage has occurred during transportation. (refer to section on pre-flight check).

! IMPORTANT

The inner and outer sprogs must exit the sail from the large cordwise zippers. The zippers must be opened when the glider is in standard break down form with both sprogs folding toward the wing tip outside the sail.

Picture 5
Assembled glider
showing dive sticks
extruding from under
surface zippers.



ASSEMBLY PROCEDURES

1. Place the glider on the ground, zipper up. Open the bag, undo ties, remove A-frame bottom padding and battens.

! NOTE

Take special care with the wires, the Litespeed S features 1x19 cable which can easily be kinked unless special care is taken.

2. Assembly the A-Frame.

! NOTE

With standard uprights, the uprights will naturally toe-in as shown in Picture 6. Hold the base bar and the upright, twisting the upright so the connection lines up.

Picture 6

Standard uprights and base bar assembly. Roll the glider over so that it is standing on the control frame.

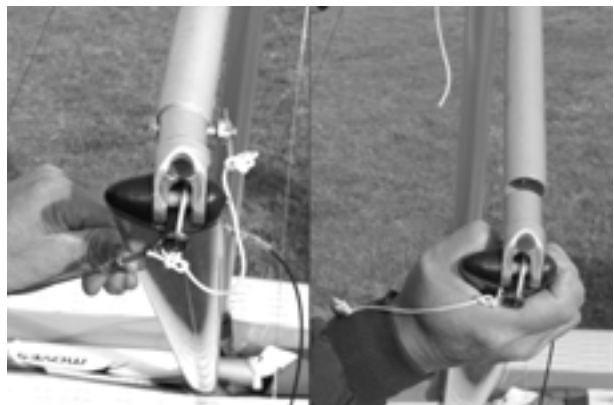

3. Roll the glider over so that it is standing on the control frame.

Picture 7

Roll the glider onto the A-frame and attach the front wire to the Bailey Block.



4. Insert the ring of the lower front wires in the Bailey Block making sure that the spring is firmly locked and the wires untwisted.

Picture 8

Attaching the front wires to the Baileys Block.



5. Insert the nose batten. The batten may need some "feeding" through the Sail by pulling the sail forward to remove any wrinkles as the batten slides into its pocket.

! NOTE

After initial assembly it is suggested that the nose batten be left in but pulled out slightly and left beside the nose plate for pack-up. Check that the nose batten sits over the lug on the keel securely.

Picture 9

Insert nose batten.

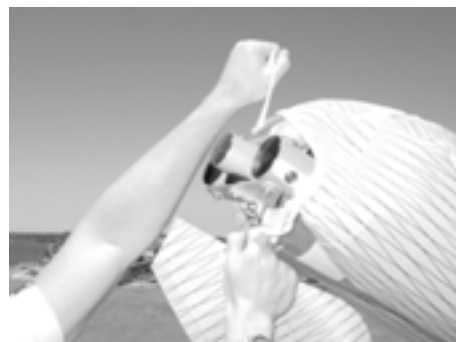

6. Carefully spread each wing making sure that you do not raise them above the keel.

! NOTE

Check bottom wires are not twisted or kinked.

Picture 10

Spread the wings.



- To tension the crossbar, pull the cord coming out of the keel aft of the sail. Check that the cable and rope are not twisted and that the spring lock is firmly locked. In strong winds the glider can be particularly difficult to tension. Have a helper gently raise and pull one wing, this reduces the pressure on the centre section and allows it to slide more freely.

! WARNING**DO NOT USE EXCESSIVE FORCE WHEN TENSIONING THE GLIDER.**

If excess force is encountered check:

- ✓ The sidewires are not twisted or kinked
- ✓ The cross bar retainer wire is not caught on the nose plate assembly
- ✓ The floating cross bar centring wire is not caught on a cross bar assembly junction
- ✓ The pull back wire or VG pulleys are not caught in the hang loop assembly

Picture 11

Tension the glider.



- The Litespeed S is equipped with a removable keel aft section. The glider can be left resting on it, facilitating the fitment of the washout struts, and battens. If desired, the glider may now be raised onto its keel to complete the assembly. This also assists with keeping the sail clean by keeping the tips off the ground.

Picture 12

Raising the glider onto the keel can make assembly easier and keeps the sail clean.

**! WARNING**

The glider may fall to one side if pushed or blown by the wind - this may result in wing tip damage. It is recommended that you only use in flat level ground and in nil wind. Use with care!

9. Insert battens gently from the root towards the mid span, battens 1-6 only. Use only gentle pressure when inserting the battens, this will greatly extend the longevity of the batten pockets. Red tipped numbered battens are for the left wing, green for the right, and blue the under surface.

Picture 13

Insert battens #1 to #6



10. Open zipper at sail tip to allow access to inside of sail. Slide fibre glass rod through end of sail and locate in the end of the leading edge. Ensure that the fibre glass rod is pushed hard against its stop.

Picture 14

Inserting tip and fitting aluminium cap.



11. Fit aluminium cup of the tip lever to the end of the tip rod and tension tip by rotating the flat end of the tip lever inboard. For extra leverage, place your thumb through the loop that is attached to the end of the tip lever. Make sure the tip lever is locked against the tip rod. Close the zipper.

! NOTE

Make sure the tip lever is consistent on both sides. The tip lever should either be above or below the tip rod when locked in place.

Picture 15

Tension the fibre glass wing tip.



12. Insert the remaining mainsail battens, 7 to 11.

13. The battens have been adjusted in the factory, but may need to be readjusted upon initial assembly. The batten tips simply screw into the end of the batten, therefore the batten tension can be adjusted by either screwing the tip in or out.

The outer batten on each wing should be fitted with additional tension. Continue to make minor adjustments to the outer batten tension until any wrinkles have been removed from the upper surface.

Picture 16

Adjust the batten end so that it slightly extends past the trailing edge.



14. Locate the inner and outer wire braced dive struts by placing them inside the sail, below the webbing loop. Note that the action of closing the cord-wise zipper creates the loop necessary to hold the strut in place.

! IMPORTANT

Do not forget this step as it is necessary for stability.

15. Insert the under surface battens (blue) into their respective pockets.
16. Fit the nose fairing using the Velcro to keep a clean trim finish.

Picture 17

Fitting the nose nappy.

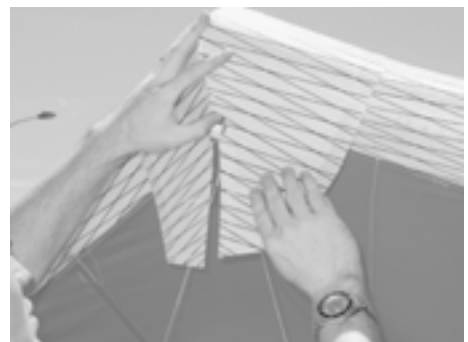

PRE-FLIGHT CHECK

As with most high performance hang gliders, much of the hardware and structure is well enclosed to give a streamlined finish to the wing. This means that you must look inside the sail to check many of the important structural components. You should develop a consistent routine that incorporates all the necessary checks. If you are distracted during the routine, you should start again to ensure nothing has been missed.

1. As you should have already attached your harness to the glider, check that it is set up correctly. Ensure that your parachute is well maintained and stowed appropriately and that the bridle runs cleanly to the carabineer which is attached vertically to the hang loops. If your harness height from base bar needs adjustment, it is best to acquire the correct length loop from your Moyes dealer.
2. Move up to the suspension system and verify that the dingle-dangle is rotated perpendicular to the keel and is free from the nose batten pocket. Check the hang loop and backup.
3. Open the under surface zip and inspect the cross-bar retainer wire. Pull the VG on and off a few times to check that the crossbars are moving freely and the VG system is operating smoothly and is tied firmly to the clip. Inspect the interior of each wing, looking at the back side of the leading edges, the crossbar, and the crossbar junctions. Check that the cross bar centring wire is free. This wire is partly loose in VG full off and should become tight when VG is 3/4 on.

! IMPORTANT

Check that all internal Velcro's are attached and are of equal length. If one side is disconnected or too loose, it may cause a significant turn.

5. Check the apex of the control frame ensuring all nuts are secure and thread is showing beyond the nut on the bolt end.
6. Sight along keel and move to the nose section, checking all nuts and bolts. Test nose catch and ensure keel batten is located correctly. Re-attach nose fairing.
7. Sight along each leading edge to confirm a similar amount of leading edge deflection (curve). Uneven curves will indicate a bent or damaged leading edge. While sighting down the leading edges check each wing for dive stick symmetry, ie. equal twist for left and right wing.

! NOTE

It is easiest to inspect for tube damage when wings are slightly opened with no battens in the sail. The entire length of the leading edge tubes can be easily seen at this stage of the set up procedure through the under surface zippers and centre zip. It is recommended to check for dents or bends at this stage of set up before each flight.

8. Move out along the wing looking and feeling for any damage. Open the zip where the side wires enter the sail and check that bottom wires are not kinked, twisted or damaged. Check the cross-bar/leading edge junction bolts and nuts and check that the ball joint is not bent. Close zip on inspection port.
9. Open the long cord-wise zippers at sprog location and check both the front and rear of each dive strut. Check that the wires are not kinked or twisted and check that the ball joint thread is not bent. Close zip.
10. Continue out to wing tip and make sure the tip levers are properly installed and that the zipper is closed.
11. Check all battens as you move along the trailing edge and be sure that the spring tips are secure inside of the trailing edge pocket.
12. At the keel, check the top VG rope and the cross-bar restraining wire. Check that rear wires are properly secured by the Bailey Block bolt.
13. Moving across to the other wing, repeat the process as you work your way back to the nose of the glider. Carefully check the front bottom wires and nose catch before inspecting the base of the control bar. Check bottom side wires for frayed strands between thimble and inner nico, and just outboard of the outer nico.
14. Ensure that the control frame assembly bolt passes through the base bar and the corner knuckle.
15. Check the rigging, nuts, and bolts are in good order and that the VG rope is threaded through the jam cleat and is secure.
16. Re-check harness, hang loops, and carabineer.
17. When finally preparing to fly, do a proper hang check ensuring that legs are through leg loops, that harness zippers work, and that all buckles or clips etc. are closed and working. Look again at your hangloops and carabineer(s).

DE-RIGGING THE LITESPEED S

Disassembly of the Litespeed S is virtually an exact reversal of the set-up procedure, however, a few important points must be remembered to avoid unnecessary damage.

1. If desired, the Litespeed S can be disassembled on its keel.

! WARNING

The glider may fall to one side if pushed or blown by the wind. This may result in wing tip damage. It is recommended that you only use it on flat level ground and in nil wind. Use with care!

Picture 18

Removing the keel assists with assembly and disassembly of the glider



2. Remove all battens starting from the tips, all the under surface battens, and the glass tips. Place all battens in the batten bag.
3. Fold the sail tips

There are a number of ways to fold the sail tips. Two such ways are shown below.

Folding the Sail Tips - METHOD 1

- Fold the leading edge back onto itself.



- Roll the sail up from the trailing edge towards the leading edge.



- Fit the sail and the outer dive strut into the boot.



Folding the Sail Tips - METHOD 2

- Begin to roll the sail tip around the leading edge.

- Continue to roll the sail until tightly rolled around leading edge.

- Fit the sail and the outer dive strut into the boot.



4. Fold the dingle dangle parallel to the keel and attach dingle dangle protector piece.

! IMPORTANT

Make sure that the Dingle-dangle is rotated in-line with the keel for pack-up to prevent serious damage to the sail and spars.

Picture 19

Turn the Dingle Dangle parallel to the keel and fit the protector.



5. De-tension the crossbar. De-tensioning the crossbar after folding the sail tips and fitting the boots helps keep the sail tips clean by keeping them off the ground.
6. When folding wings, go to the rear of the keel and grab the trailing edge at number 3 batten on either side and lift in and up so that the centre section can slide up the keel without binding. Ensure that leading edges and keel remain in the same plane and that no sail has caught between wing and keel.

7. Fit rear keel protector piece over bailey block assembly.

Picture 20

Fitting the keel protector piece.

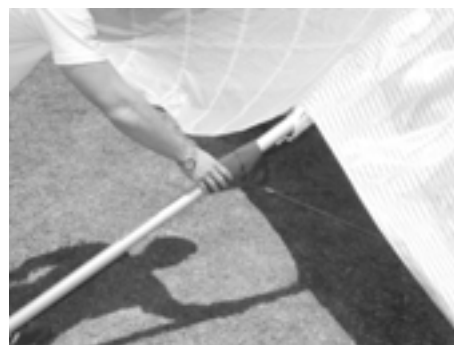

8. Fold and roll the sail parallel with the trailing edge.

Picture 21

Rolling the sail.



9. Attach ties loosely around glider, going from wing tip to nose, and then tighten the ties, moving from nose to wing tip, adjusting the sail so that the leading edge Mylar inserts overlap smoothly with no kinks, as shown.

Picture 22

Attach ties.

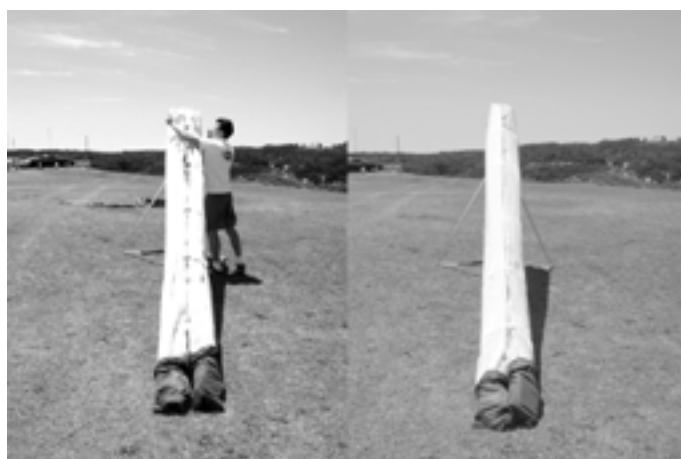

10. Put the glider bag over the glider, and then lay the glider over on its side.

11. Disassemble control frame. Fold base tube out and lay the entire control frame assembly back onto the keel. Open the ties and re-secure them over the control frame, enclosing the frame inside Mylar. Fit padding to the bottom of control frame. Tuck wires and bars neatly inside the sail. Pull the hang loop from in front of the uprights so as not to jam the hang loop between the keel and the sail.

! IMPORTANT

Special care must be taken with cables. The Litespeed S features 1x19 cable for increased strength and low drag, but this cable is very easily kinked unless special care is taken.

Picture 23

Fit Base Bar Padding.

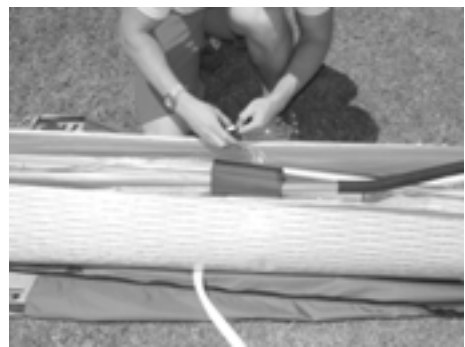

12. Place battens between leading edges with the camber to the tail end, then firm up all ties and smooth out the rolled sail before closing the zip.

Picture 24

*Pack Battens
between leading edges.*



FLYING THE MOYES LITESPEED S

Take-off

The Moyes Litespeed S has slight tail heavy static balance and therefore is very easy to launch in calm or windy conditions, and on steep or shallow slopes. The nose should be held slightly above horizontal with the wings level. Your run should be a smooth acceleration with appropriate pitch control for the situation, and once a safe excess of minimum air speed is acquired, a slight easing out of the bar will give a smooth lift-off. In winds in excess of 10-15 mph (16-24 kph), some wire assistance may be required.

Using the VG for Take-Off

In some situations it is recommended to launch the glider with up to 1/3 VG. It should be noted that the Litespeed has an enormous VG range, and 1/4 VG is equivalent to VG loose on many other gliders. It is important never to use more than 1/3 VG, as the glider will become very difficult to control if turbulence is encountered during or just after take off.

In windy conditions, some VG can help the glider penetrate forward away from the take-off and away from any danger. With 1/3 VG the glider has a more solid feel and it becomes more difficult to over-control or produce pilot induced oscillations. On the other hand, many experienced pilots prefer to fully open the VG during windy or turbulent take-offs to allow for maximum control. For your first windy take-off on the Litespeed it is recommended to use 1/4 VG.

For light wind or nil wind take-offs some VG can help the glider lift sooner making take-off easier. This is especially helpful for take-offs on shallow slopes as the gliders increased performance will allow for a shorter take-off run. Its important to note however that with more VG, the glider becomes more prone to tip stalling, so if VG is used during take-off special care must be taken to keep the wings very level.

For cross wind take-offs a hang glider becomes much more vulnerable to tip stalling, so usually its best to launch with the VG fully opened in these situations.

Litespeed S Variable Geometry

The Litespeed S features a very large VG range with a sail and frame construction that makes this VG extremely powerful and effective. The initial pull of the VG has the most significant effect on the sail tension. When VG is half on, much of the washout has already been taken out of the wing and with 1/2 to 3/4 VG the sail is already beginning to rest on the dive struts in normal flight. The remaining 1/2 to 1/4 of the VG travel begins to take the washout out of the root and mid span. The extra sail tension has the effect of flattening the battens slightly and producing a better high speed airfoil. The VG system also operates the inboard dive strut compensator system allowing for increased pitch stability and safety margin when the VG is not full tight. The Litespeed S features a similar enclosed VG system to recent Moyes gliders, only with the addition of complete bearing pulleys featuring a double pulley assembly on the keel and a second double pulley assembly mounted inside one upright. The pulley assembly in the upright features miniature needle bearings while the pulleys on the keel are conventional rolling ball bearings. This system of bearings makes the VG very easy to operate allowing the pilot to fine tune the wing with minimum effort.

Thermalling the Litespeed S

Bank angle and Airspeeds

The Litespeed S is designed to thermal comfortably at a bank angle of 30 degrees and an airspeed 4mph (6kph) above stall speed. It can be beneficial to climb rate to further reduce the airspeed but some high siding is required to maintain a shallow bank angle. The sink rate of the glider improves only very slightly if the airspeed is reduced to the limit and at such a low airspeed there is some loss of control authority. Therefore it is only recommended to thermal the glider on the stall limit in weak smooth thermals. In strong or turbulent conditions it's strongly recommended to fly with a good amount of excess airspeed to achieve a safe amount of control to avoid stalling in thermal gusts, (see more below under 'safety in turbulence').

One of the Litespeed S's high points is its coordination at high bank angles. The glider can be banked to 50 or 60 degrees while maintaining a low sink rate with minimum pilot effort. As the bank angle is increased, little or no high siding is required, and at higher circling airspeeds it can be necessary to roll in to maintain the bank angle. In order to coordinate a high bank angle, the control bar position needs to be pushed out slightly more than when thermalling at lower angles of bank. It is recommended to pay special attention to the airspeed indicator during initial thermal flights on your Litespeed S. This will give you a good feeling for the relationship between control bar position, bank angle, and airspeed for this particular glider.

Thermalling with VG

It is possible to thermal the Litespeed S with up to 1/3 VG and experience a noticeable gain in sink rate by doing this. However, when the VG is pulled 1/3 tight the Litespeed S needs more significant high siding, especially at low bank angles. Handling is also quickly lost if the VG is pulled any tighter. Thermalling with VG is a trade off between handling and sink rate performance, and many top competition pilots choose to always thermal the Litespeed with full loose VG to save energy and provide fast roll rates. The glider will sink better with some VG but also becomes less comfortable and increasingly difficult to fly. In turbulent conditions it is recommended to fly with VG loose to maximise stability and control. Often this increase in control is more beneficial to climb rate as a pilot can easily centre and stay in the thermal core.

There are situations when the Litespeed is best thermalled with a small amount of VG, and we recommend that the pilot experiments with this to find what best suits him/her self.

Gliding the Litespeed S

The greatest advantage of the Litespeed S is its glide performance, particularly at high speeds. A best glide ratio of 15:1 can be achieved in still air at low speed, 28mph (47 km/h) with optimal weight range. However if headwind is encountered, or reasonable thermal strength is expected, the pilot needs to dramatically increase air speed to maximise the flight performance. In competition, pilots are gliding their Litespeed S at speeds up to 50mph (80km/h) to optimise cross country speed. With its flat washout distribution, the Litespeed S can still achieve between 9 and 10 glide points at these speeds.

VG Position for Gliding

With full VG, the Litespeed S sail has far more tension than on previous Moyes gliders. The Litespeed S is intended to be tuneable for all situations, and with VG full tight the glider becomes quite difficult to control. The full tight VG setting is only intended for high-speed glides, and especially high-speed diving into goal. At the lower end of the speed range there is little glide advantage to be had flying full tight setting. Maximum glide will not change from 3/4 VG to full tight. When floating around a ridge or slowly gliding down wind, the pilot will find no advantage flying full tight. The only consequence will be loss of handling. However, if penetrating a strong wind, full VG will give the pilot a noticeable glide advantage and handling will be manageable due to the higher airspeed.

Safety in Turbulence

A hang glider is a tailless aircraft and thus pitch stability is limited to a degree. One of the main design goals of the Litespeed S was to maximise the pitch stability with a strong rigid dive strut system and the compensated inner sprog. Moyes are extremely satisfied with the strength and stability of the Litespeed S. However there still remains the risk of a tuck or tumble if extreme turbulence is encountered, and it's important that the pilot understands ways to minimise this risk.

Airspeed

Many experts believe that the largest cause of tumbling is loss of airspeed due to turbulence. When the glider loses its airspeed it becomes increasingly vulnerable to forward rotation and a tuck or tumble. The glider can hit a surge of lift, which raises the nose, and even if the pilot holds the control bar in position, the glider will climb and quickly lose airspeed. It is at this point that the glider is vulnerable to this forward rotation if sudden sink or rotating air is encountered.

It is therefore paramount that the pilot maintains sufficient airspeed in turbulence. If the glider hits a surge of lift, which raises the nose, the pilot should quickly react to bring the glider back into a normal flying attitude and restore the lost airspeed.

Body Position

The most vital thing for a pilot to do in heavy turbulence is to maintain a strong grip on the control bar. The pilot remains safest when the control bar is held tight and close to the body at or just below the pilot's chest. If extreme turbulence is encountered the pilot should apply a force pulling his/her body toward the base bar. This means that if a sudden weightless or negative G situation occurs, the pilot can stay pinned to the base bar achieving a forward centre of gravity, which greatly aids in producing a quick recovery.

VG in Turbulence

Most high performance hang gliders produce a stronger positive pitch moment through negative angles with a loose VG setting as opposed to a tight setting. The least amount of positive pitch moment generally occurs with VG 3/4 tight. The Litespeed S's compensator system allows the glider to produce a particularly strong pitching moment in the loose VG settings. If a significant amount of turbulence is encountered it is best to release the VG to full loose or 1/4 VG. While in turbulence make sure you keep a very firm grip on the control bar, and do not sacrifice this strong grip to release the VG. It is best to wait for a safe moment and then release.

When leaving a strong thermal one can expect significant turbulence at the edge of the thermal. Many pilots like to pull 3/4 VG to allow more control over the glider in this turbulence, however it must be remembered that this is the VG setting, which produces the lowest positive pitch moment at negative angles. Many situations occur during regular flying when a pilot will enter pre-recognised turbulence, such as entering a strong thermal or entering the lee side of a mountain. The pilot can greatly increase his safety by entering this foreseen turbulence with an appropriate VG setting.

Flying the Litespeed S in Rain

Flying in rain can cause significant changes in glider behaviour. It is strongly advised that you avoid deliberately flying in rain. As water beads up on the leading edge, the stall characteristics of the wing begin to change. If rain is encountered while flying your Litespeed S, keep airspeed well above stall, especially near the ground. If the wing stalls you may need a significant pull in of the bar to lower the angle of attack enough to restore normal airflow. When landing, avoid any turns close to the ground, as a wet glider will lose significantly more height in a turn. Fly a faster final approach than normal, and be ready to flare aggressively as soon as the wing begins to stall.

TUNING HINTS

The staff at Moyes are more than willing to provide advice or help in the tuning of your glider. Feel free to contact Moyes at:

T: +61 (0)2 9316-6466

F: +61 (0)2 9316-8488

E: moyes@moyes.com.au

Trim Adjustment

Upon delivery, your Litespeed S should have been test flown by a factory test pilot. Part of this test fly procedure is to check and correctly trim the glider. The designated CG location is measured from the front of the keel tube (this is the front of the tube exclusive of the end cap) as shown on the specifications page. Before changing the trim position of your glider it is best to check where your hang point is in relation to the designated trim. Each hole position is equivalent to approximately a 1.5mph (2.5kph) change of trim speed.

! IMPORTANT

Never change the trim position of your glider upon delivery before test flying. All changes in trim position should be carried out in increments of 1 hole at a time.

If you have excessive pitch pressure while gliding with full VG, it could be that your trim position is too slow (too far rearward). Moving the trim forward even 1 hole will cause a noticeable reduction of pitch pressure.

Most competition pilots prefer to fly with a more rearward CG location. Pilots favour this as they can experience less push out pressure when circling and thus the glider becomes more comfortable to thermal. This lets the pilot to fly with lighter pressures allowing for more sensitivity to the moving air.

Fixing Turns

It is possible for a glider to develop a turn with age due to uneven stretch or uneven shrinking of the sail due to flying or UV exposure. It can be noted that Dacron materials are more vulnerable to stretch and shrinkage. If your glider develops a turn that previously did not exist you should check the following:

- Check battens against template and double check that both sides are the same
- Remove and thoroughly check both leading edges for any bend or damage
- Accurately sight along the keel to check for any bends or damage
- Double check that no wires or thimbles were twisted, bent or kinked in flight
- Make a double check that the hang loop assembly was correctly positioned during flight and was not caught on the nose rib pocket

Fixing a Spiral

If your glider falls into one turn direction more than the other you have a spiral turn. If you check carefully you will notice that your glider will also have a gentle turn with the VG off in straight flight. With the Litespeed, this kind of turn becomes more noticeable with VG 1/3 on.

The first thing to adjust is the white plastic back section endcap. This endcap houses the tube in which the fibre glass tip inserts. If you have a right spiral you should rotate the right side white plastic down and back (ie. anticlockwise if you are looking from the wingtip to the nose and the glider is in a flying attitude, top surface up). There are pre-drilled holes in the white plastic to secure the screw. The neutral position is marked with a pen on the plastic.

Your Glider Turns VG Full On

If your glider has a turn only when VG is 3/4 on to full on, the turn is caused entirely by uneven dive strut height. To fix this kind of turn you should adjust the outboard dive struts, as these have the greatest effect on turning and are more sensitive to adjustment.

If you have a gentle left turn, the first step is to raise the right side outboard dive strut 1/4 turn. This is best done when the glider is fully assembled and the dive strut folded toward the leading edge inside the sail to release tension from the cable. Remove the ring and clevis pin securing the dive strut to the threaded cone. The threaded cone has 4 holes and can be rotated and fixed in 1/4 turn increments. To adjust the right side up 1/4 turn, you need to unscrew the cone 1/4 turn and re-locate the holes in the cone with those in the dive strut. Replace clevis pin and ring and re-position dive strut in the loop on the sail.

If your glider does not fly straight after this adjustment, you need to lower the left side 1/4 turn. This process is the same as raising 1/4 turn, only the cone needs to be screwed in rather than out.

For a right turn, raise the left outboard strut 1/4 turn, and if adjustment is still needed lower the right side 1/4 turn.

Continue this process until the glider is flying straight. If the process needs to be repeated more than twice consult your local Moyes dealer or Moyes Delta Gliders for advise.

! WARNING

The adjustment of the outboard dive strut on the Litespeed S is considerably more sensitive than the inboard dive strut, and is more sensitive than the Moyes CSX. Special care must be taken when self adjusting your dive struts and it is paramount that the dive struts are not lowered as this will cause a reduction in pitch stability.

PERFORMANCE TUNING

This section has been included in the manual to ensure that pilots have the right information about modifications for performance and handling. The Litespeed S's have a very nice set-up out of the box, and each glider will have been flown and possibly modified to ensure it has the right characteristics.

! WARNING

Some modifications listed below will bring the glider out of its certified configuration and may deem the glider less safe in turbulence.

The Moyes Litespeed S is a third generation topless glider and differs considerably from the first generation gliders. There are steps that can be taken to slightly increase high speed glide performance, but unlike earlier topless gliders, this does not simply involve lowering the dive struts. It is no secret that one could compromise the safety of early topless gliders and achieve better performance, however this old rule does not apply to the Litespeed S. The nature of the sail and stability system allows for an extremely low amount of twist with excellent safety.

The dive stick adjustment on the Litespeed S is very sensitive. If lowered even slightly, the glider will become less stable, and performance gains are absolutely minimal.

Simply: **DO NOT LOWER YOUR DIVE STICKS.**

Eccentric ring adjustment.

The Litespeed S has a series of eccentric rings along the length of the leading edge tubes which can be rotated to change the characteristics of the glider. Essentially, two sets of these rings can be used for fine tuning. The eccentric ring at the exit of the fibre glass tip (refer to 'fixing a spiral') can be rotated backward to lower the angle at which the glass tips exit the leading edge. Rotating the fibre glass exit ring will reduce the pitch stability of the glider. There is also an eccentric ring located in the mid-section at the first major leading edge step down. If the mid sleeve eccentric ring is rotated backward (fat section to the bottom) the outer leading edge will angle slightly up. Adjustment of these rings has an effect on both spiral stability and bar pressures. If done correctly, you can customise your pitch pressures and thermalling characteristics of the glider with small adjustments.

! WARNING

Be sure to fully read this section before making any modifications to the original glider set-up.

How to Adjust the Eccentric Rings.

The mid section ring can be adjusted freely with no consequence to safety of the glider. Do not rotate these rings beyond 45 degrees; any more rotation is unnecessary and will not provide any advantage.

All references to adjustments are made from the centre location. On the mid section rings the centre location is the vertical hole that aligns with the horizontal stopper screw. On the fibre glass exit ring, the centre location is the point at which the retaining screw on the back section aligns with the pen mark on the ring.

Some Litespeed S's have been produced with several adjustment holes already drilled into the plastic rings. These pre-drilled holes allow for adjustments forward and backward from the centre location. If you do not have a pre-drilled hole in your desired location you need a 2.5mm drill to make a hole, allowing the screw to indent a thread. Many Litespeed S's have been slightly adjusted during the test flying and the eccentric rings may be slightly rotated on arrival of your glider.

To adjust the eccentric rings, it is best to first remove the mid section and back section leading edge. Before attempting this, it is best to consult the relevant assembly drawing inside this manual.

To dismantle, remove the sail retaining clevis pin at the back section end, and the 3/16 pin (or possibly bolt), which acts as a stopper for the back section and secures the mid section. There is a small screw which locates the mid section eccentric ring, which also needs to be removed. Once this is completed, the mid section and back section can be removed through the sail inspection zipper.

Once the mid section and back section are removed you can take a close look at your current set-up and begin to assess what adjustment is desired.

If you find there is too much high siding, you can rotate the mid section rings to as much as 45 degrees backward (the fat section to the bottom). It is best to rotate in small increments, as the rings are very sensitive.

Set-up Suggestions

For pleasant thermalling, a good combination is to have the fibre glass exit rings straight (vertical), and the mid section rings 30 to 45 degrees (20mm) backward. This will slightly increase the gliders pitch pressures. Some gliders leave the factory with this set-up, so this may be your starting point.

GLIDER CARE

Your Moyes Litespeed S will require very little in the way of maintenance if you take a little extra time and care with your day to day treatment and use.

Storage

Keep the glider in its bag in a cool dry place. Store the glider off the floor or ground and free from contact with oils, solvents or acidic substances. Always dry the glider completely before storing. If this is not possible, ensure that the glider bag is off or open and that the sail is loose enough for air to circulate. Dry completely, as soon as possible.

Sail Care

It is important to keep the sail clean and free from salt if you fly near the coast. Regular rinsing with fresh water will achieve this but for thorough washing a mild detergent may be used provided it is completely rinsed off the sail. For more serious stains consult your local sail-maker or Moyes dealer.

Always ensure that all protective padding is properly placed in correct location for transport or pack-up. Even one small trip with missing or incorrectly located padding is enough to wear a small hole in the sail.

For small tears apply sail repair tape to prevent fraying. Unless the tear is at a stress point or along the trailing edge it will not tend to run or expand.

Sun and exposure to the elements will deteriorate the sail more rapidly than hours of flying. It is recommended to minimise sun exposure and exposure to UV radiation. If possible set up the glider in shade and minimise the time in which the glider is open to the elements. Note that Dacron or Powerib sails are considerably more vulnerable to UV deterioration than the new PX Mylar. It is important to carry the glider in its bag on well padded roof bars with at least three points of support.

If you take just a little extra care when packing up and transporting the glider, it will maintain its condition and performance for many more enjoyable hours.

Battens

Never force the battens into their pockets. Insert them gently to avoid damage to the sail and wear to the batten ends. If battens are pushed into the pockets too fast the plastic batten ends will heat to the point of slightly melting and create unnecessary wear on the batten pockets. Sand in the sail or on the battens will cause abrasion in the pockets. Always pack the highly cambered battens (nose to batten 5) into the batten bag as a unit - never one at a time. This will avoid flattening the camber. Store the battens securely between the leading edges with the camber to the very end so that the tie downs for transport do not pull across the camber.

If reshaping is required, take care to avoid overworking the tube as this will soften the alloy causing the battens to lose shape more easily in the future.

Wires and Attachments

At the first sign of frays or kinks the wire should be replaced. Stainless steel cable work-hardens from bending, especially where it enters or exits a nico sleeve. The shrink tube covering the nico sleeve should be peeled back periodically to inspect the cable. Constant exposure and set-up on rough and rocky ground will shorten the riggings life. Wires are not expensive and are simple to replace. They are also a vital structural member of the hang glider. If the glider is periodically exposed to salty air, some rust may form on the cable. This is nothing to be concerned about and is caused only by some impurities mixing up in the cable during cable manufacture. The cables are stainless steel and will not corrode due to ocean air exposure.

Tubing and Bars

Once again contact or immersion in salt air or water is a major concern and will require removal of end caps and a thorough flushing and drying. Corrosion and electrolysis set in amazingly quickly and will dramatically reduce the strength and life of the parts involved. Follow the maintenance schedule conscientiously. Examine the bars for dents, bends, wear spots and corrosion every pre-flight check. If any damage is noticed, replace the bar, but also determine how that damage was caused and take steps to avoid repeat damage occurring.

Hardware and Bolts

The bolts can be bent in a crash or hard landing. These should be replaced. All bolts should show exposed thread above the locknuts.

! IMPORTANT

Never try to straighten a bent bolt. Straightening the bolt will cause significant work hardening and will dramatically reduce strength. All Moyes hang gliders use specially sourced aircraft quality bolts throughout the airframe, and should only be replaced by the exact bolt type available from your local Moyes Dealer.

Special Note to Coastal Fliers

The Litespeed S uses thin wall 7075 tubing throughout the airframe, which is considerably more vulnerable to corrosion than the 6061 alloy used on previous gliders. The 7075 suffers corrosion for two reasons. 7075 has a thinner wall thickness (0.9mm compared to 1mm) which means that a small amount of corrosion has a larger effect. 7075 alloy also contains a large portion of copper, and this is the most significant reason for corrosion.

If the tubing is ever directly exposed to salt water it must be thoroughly rinsed with fresh water as soon as is possible. If your glider is exposed to coastal air you must rinse the inside and outside of the tubes with fresh water once every 6 months. If your glider is stored near the coast you need to keep your glider in a dry location such as a closed garage.

It is possible to put a film of linseed oil on the inside of the leading edge tubes. This will considerably help in the prevention of corrosion. To do this the leading edge tubes must be removed from the glider. Fully disassemble the leading edge removing all sleeving. Pour a small amount of linseed oil into each tube and sleeve rotating the tubes as you pour to entirely coat the inner wall. After this is done, apply a second coat by wetting a cloth with linseed oil, attaching it to a broomstick, and pushing it through the length of the tube. Note that the front section leading edge has a series of inner nylon rings, thus the cloth must be pushed through each end individually.

MAINTENANCE SCHEDULE

Every 10 Hours

1. Check all battens against airfoil template.
2. Sight through the sail zippers to inspect for any tube dents or bends.

Every 50 Hours (or Six Monthly)

1. Inspect the sail. Check the stress areas and apply sail repair tape where necessary. Special attention should be directed to the wire slots.
2. Inspect all cross-bar wires, fittings and hardware.
3. Check all bars/tubing for damage or possible wear caused by set-up, fold-up or transportation.
4. Inspect all rigging for frays and other signs of damage or deterioration and replace if necessary.
5. Inspect the carbon spar at the centre section junction by removing the bolts and stainless steel caps and check that the titanium bushings are still affixed to the spar.
6. Replace lower side wires every 50 hours or 6 months

Every 100 Hours (or Annually)

This inspection is best carried out by your local Moyes dealer or the Moyes factory. The sail must be removed allowing for all components to be exposed and thoroughly examined.

Check the sail for any wear or abrasions. Small holes in low stress areas such as the under surface can be repaired with sail repair tape. Damage in higher stress areas such as the trailing edge or centre seam need to be fixed by a professional sail maker. It is always best to consult your local dealer or consult Moyes directly about repair of sail damage.

Thoroughly inspect all tubing for dents, bends and corrosion and replace when necessary. All bolts should be examined closely for wear and bends. Remove all cross bar junction bolts and A-frame top bolt and closely examine for bends and corrosion. If there is any damage, replace.

Sight through the inside of each carbon cross bar as damage may show only on the inside. You may need a torch to assist in this inspection. Run your hands around the outside of each spar across the length to feel for any cracks. Damage to the carbon spar usually shows up as a long significant longitudinal crack which can be seen on close inspection and can be easily felt by hand. Carefully examine the titanium centre bushings and stainless steel pins for deformation or damage. You will need to remove the centre bolts and pins to properly complete this inspection.

SAIL REMOVAL

We strongly suggest that you do not attempt this if you are not familiar with this glider. We recommend that you take the glider to your nearest Moyes dealer for such procedure.

1. Lay the glider flat on the ground and unzip the glider bag, roll glider so that it is top-side up, remove all the ties, and spread the wings a few feet.
2. Remove sail attachment screws from the nose of the glider and rear of keel pocket.
3. Undo central zipper entirely and remove plastic cable tie at nose of sail.
4. Disconnect bottom side wires from bottom of down tubes by removing the hinge pin. Be sure not to lose any of the hardware as the pin is removed.
5. Disconnect the rear wires from the keel by undoing the Bailey block bolt.
6. Open the tip zippers and disconnect sail attachment straps from the clevis pins at the end of each leading edge tip.
7. Carefully slide frame forward and out of sail.

To re-assemble the glider reverse the order in which it was disassembled.

CHECKING THE LITESPEED S STABILITY SYSTEM

Step One

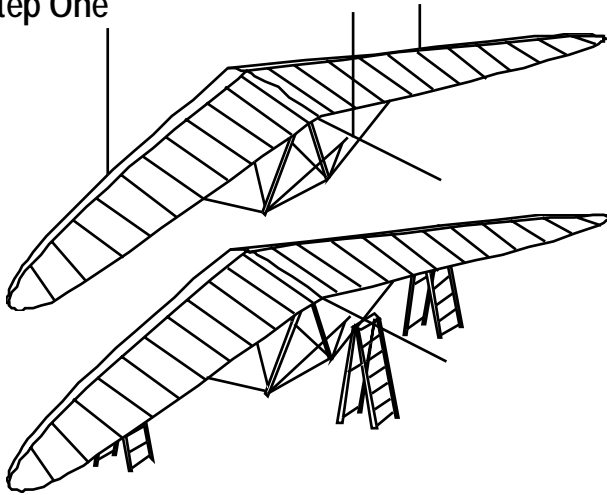

Option One

Hang the glider from three points to simulate its flying position.

The three positions are;

1. the keel behind the rearwires,
2. the left side wing where the bottom side wire exits the sail, and
3. the right side wing where the bottom side wire exits the sail.

Option Two

An alternative to hanging the glider is to raise the glider by using three support structures, such as ladders.

Step Two

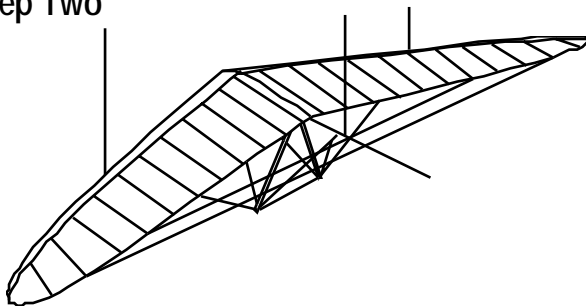

With the VG system fully applied, tie a piece of thin thread between the two sets of batten ends (number 8 and 10 battens), ensuring the string is taut.

Step Three

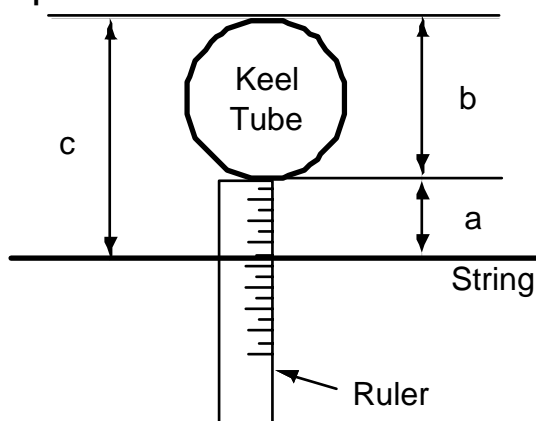

Obtain the correct measurement for your glider from one of the tables below. The measurement is the distance between the string and the top of the keel.

NOTE: If the string is fouled by the keel, it may be necessary to remove the rear keel section and tape a straight edge to the top of the keel.

a = Distance between bottom of keel and string

b = Outer diameter of keel (42mm)

c = a + b (obtain the correct distance from the tables on the next page)

! IMPORTANT

All measures are taken from the top of the keel, if string line falls below the keel, measure from bottom of keel and add the diameter of the keel (42mm).

PURCHASE RECORD

Glider Model and Size	Litespeed S – 3 3.5 4 4.5 5
Manufactured Date & Serial Number	Date: _____ No: _____
Mainsail / Colours	Main : Px / 205 Sq Colours :
Options:	Zoom Carbon Inserts Back sections Dive sticks Battens
Dealer Name & Address	_____ _____

THE MEASURED STABILITY SETTINGS AT THE TIME OF MANUFACTURE OF YOUR GLIDER ARE INDICATED ON THE CHART BELOW. THE STABILITY SETTING LISTED RELATES ONLY TO THE SERIAL NUMBER OF THE GLIDER LISTED ABOVE.

LITESPEED S – STANDARD A-FRAME

Model	VG Setting	Batten Numbers		
		8	9	10
Litespeed S 3	Tight			
Litespeed S 3.5	Tight			
Litespeed S 4	Tight			
Litespeed S 4.5	Tight			
Litespeed S 5	Tight			

LITESPEED S – ZOOM A-FRAME

Model	VG Setting	Batten Numbers		
		8	9	10
Litespeed S 3	Tight			
Litespeed S 3.5	Tight			
Litespeed S 4	Tight			
Litespeed S 4.5	Tight			
Litespeed S 5	Tight			

! WARNING

The correct stability setting is of the utmost importance to the pitch stability and safe flying characteristics of your glider. The stability settings have been set by the factory and should not be adjusted.

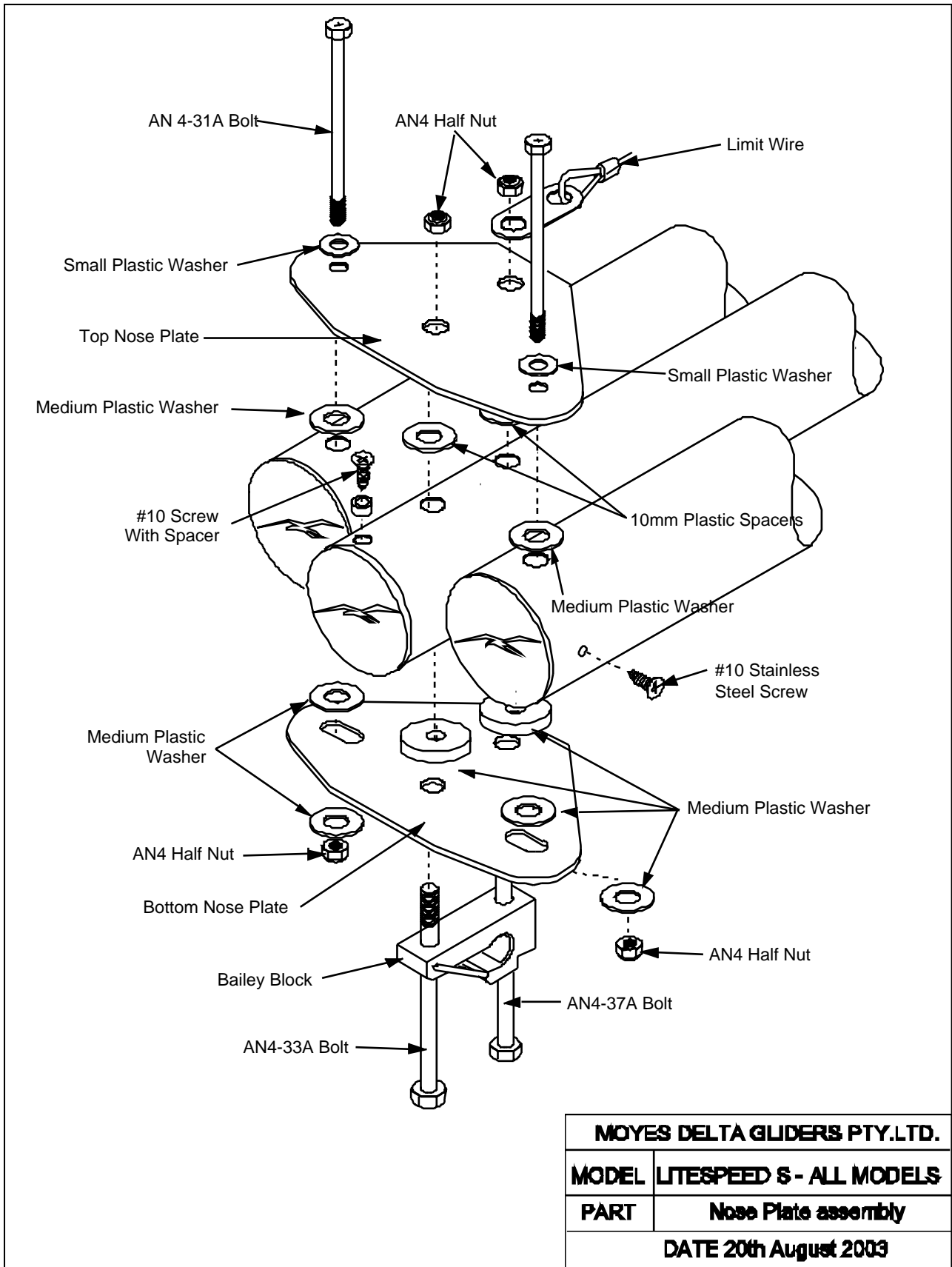

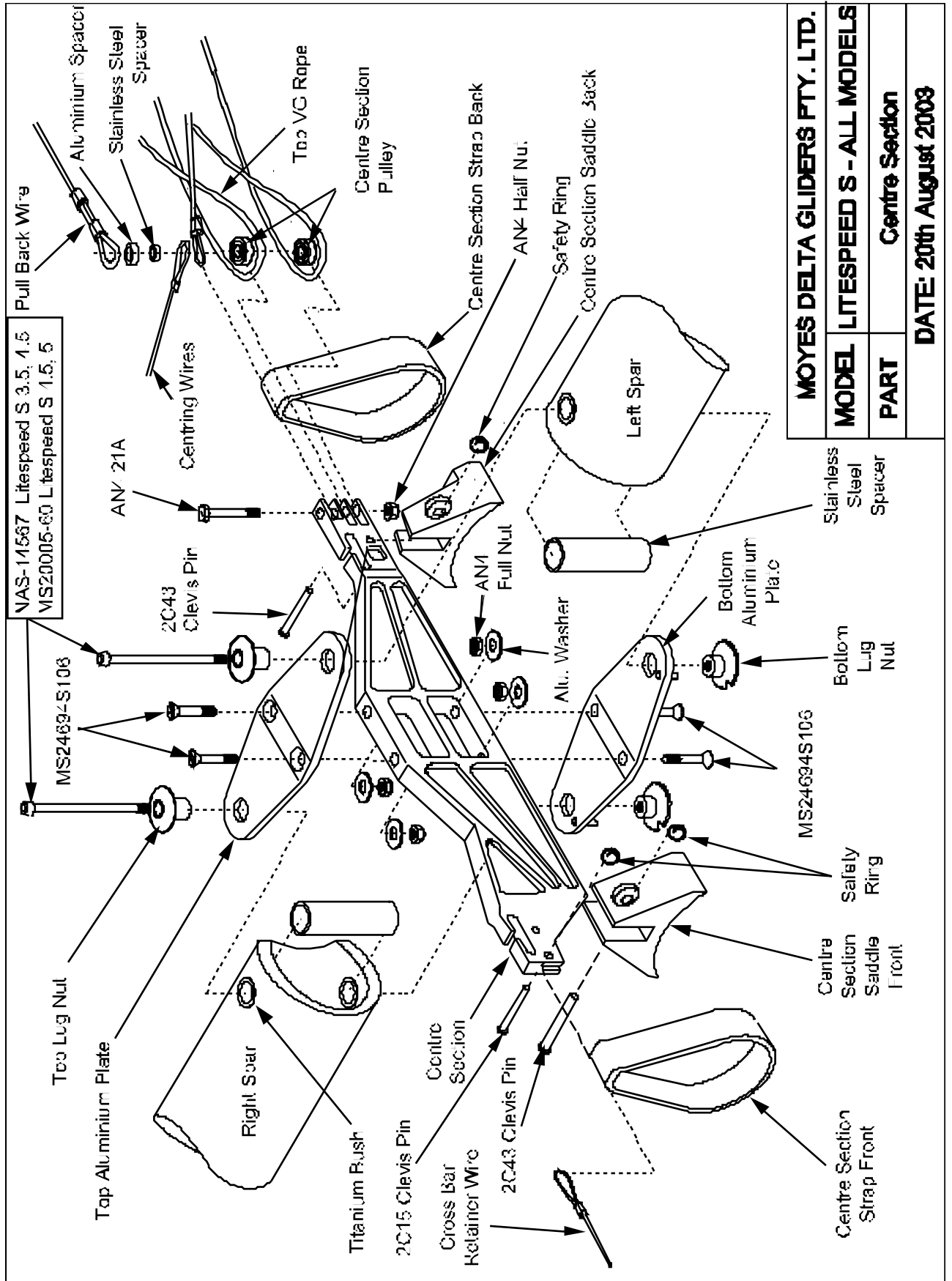

MOYES DELTA GLIDERS PTY. LTD.	
MODEL	LITESPEED S - ALL MODELS
PART	Centre Section
DATE: 20th August 2008	

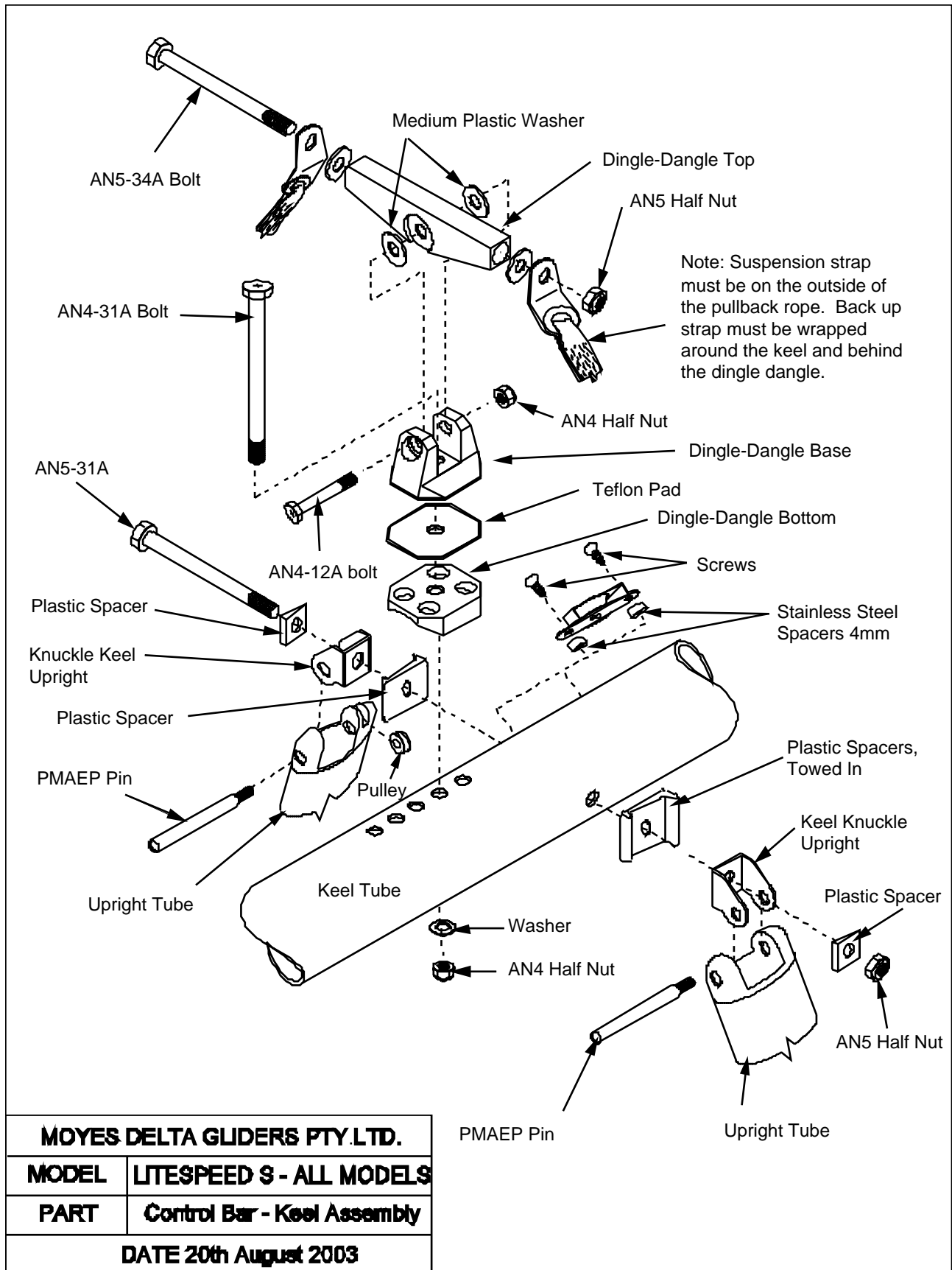

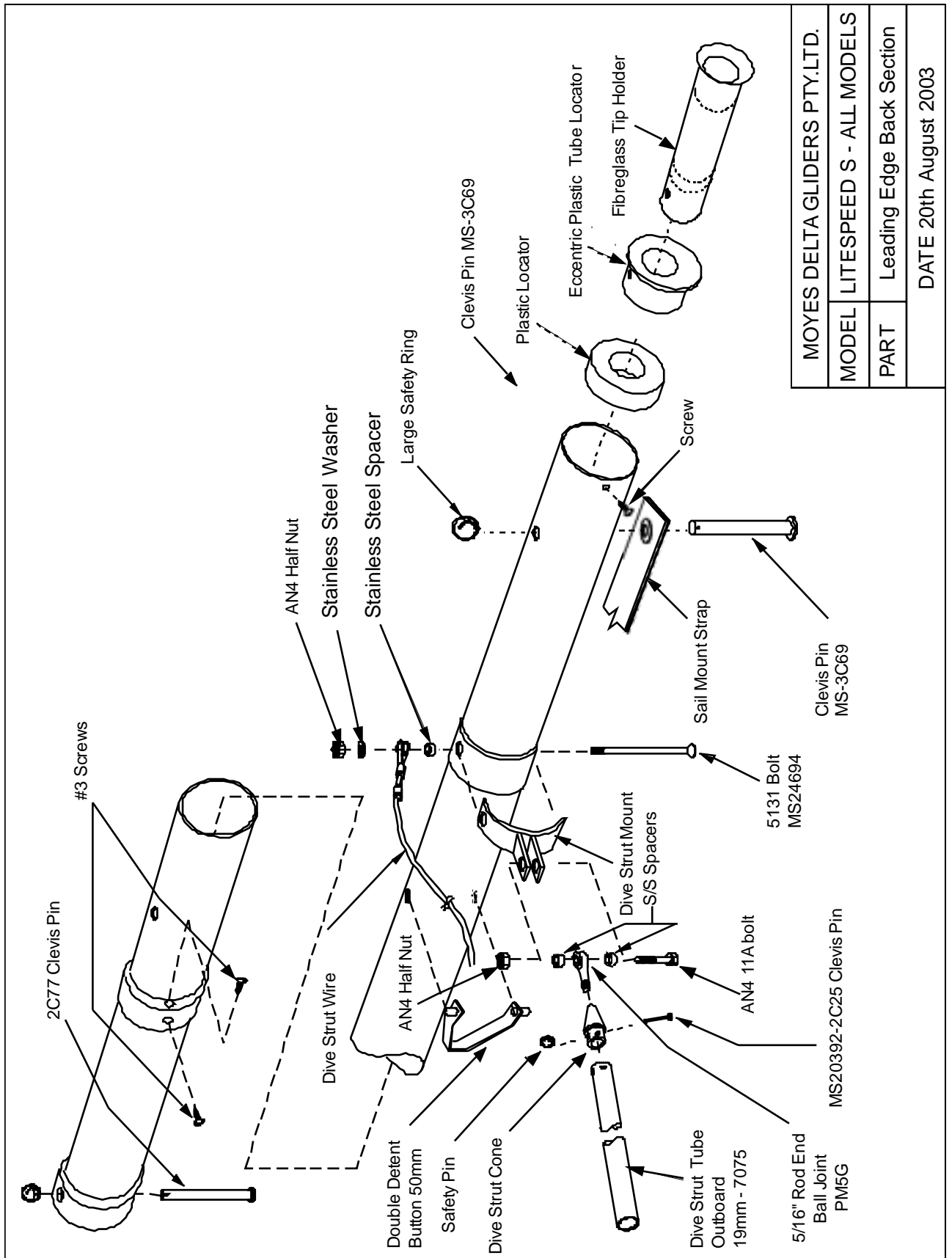

MOYES DELTA GLIDERS PTY.LTD.	
MODEL	LITESPEED S - ALL MODELS
PART	Leading Edge Back Section
DATE 20th August 2003	

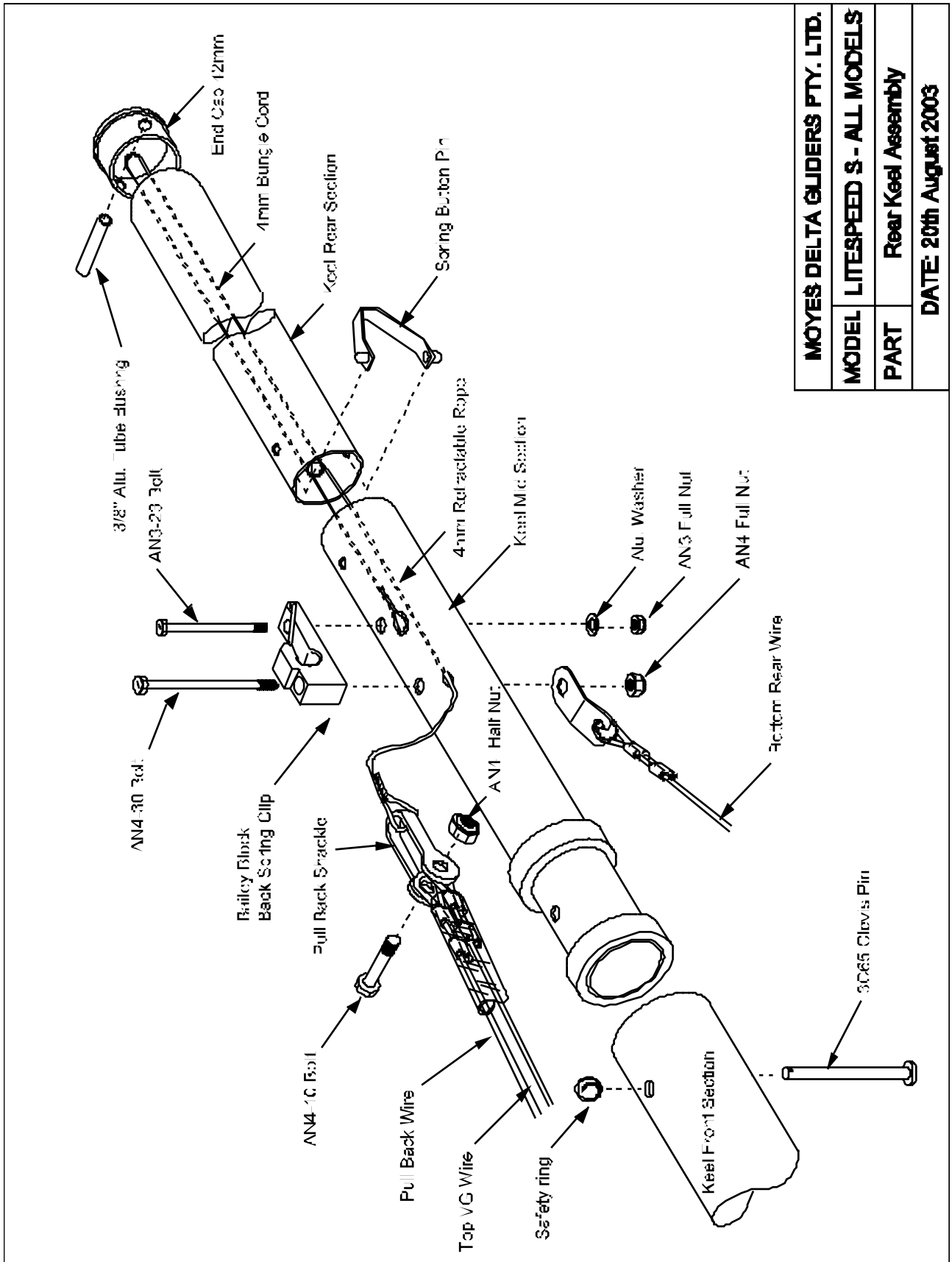

MOYER DELTA GLIDERS PTY. LTD.	
MODEL	LITESPEED S - ALL MODELS
PART	Rear Keel Assembly
DATE: 20th August 2003	

